

Content

1. Safety Notice
2. Installation Drawing
3. Technical Data Table
4. Circuit Diagram
5. Installation and Debugging
6. Controller Operation/Instructions
7. Maintenance
8. Troubleshooting
9. Note

1. Safety notice

For safety, please follow the instructions below:

! All units must be installed by qualified personnel.

! Units must be installed in compliance with local wiring codes.

! The power supply input is 220V/50Hz AC.

! The AC input must be connected to a suitable ground leakage device and the fuse rated for 1.5-2 times max current.

! The AC input wire if damaged must be changed by qualified personnel only.

! Ensure that the AC input plug and socket are properly connected and the unit is well grounded.

! The controller must be fitted in a dry location where it can easily be observed and operated.

! The controller is set to its factory default settings and does not need to be reset; please refer to the controller operation/instructions section.

! The water pump used with the unit must have approved certification

! Water temperature setting:

Environment temp: $\geq 18^{\circ}\text{C}$

Water temp: $50^{\circ}\text{C} \sim 55^{\circ}\text{C}$

Environment temp: $\leq 18^{\circ}\text{C}$

Water temp: $50^{\circ}\text{C} \sim 60^{\circ}\text{C}$

! At the above temperatures, hot water for domestic use should be mixed with cold water to avoid burns.

! Turn power off to the unit if it is not being used for a long time and drain the unit. For full instructions refer to the controller operation/instructions

section.

! The manufacturer cannot be held responsible for damage caused by improper operation.

2. Installation drawing

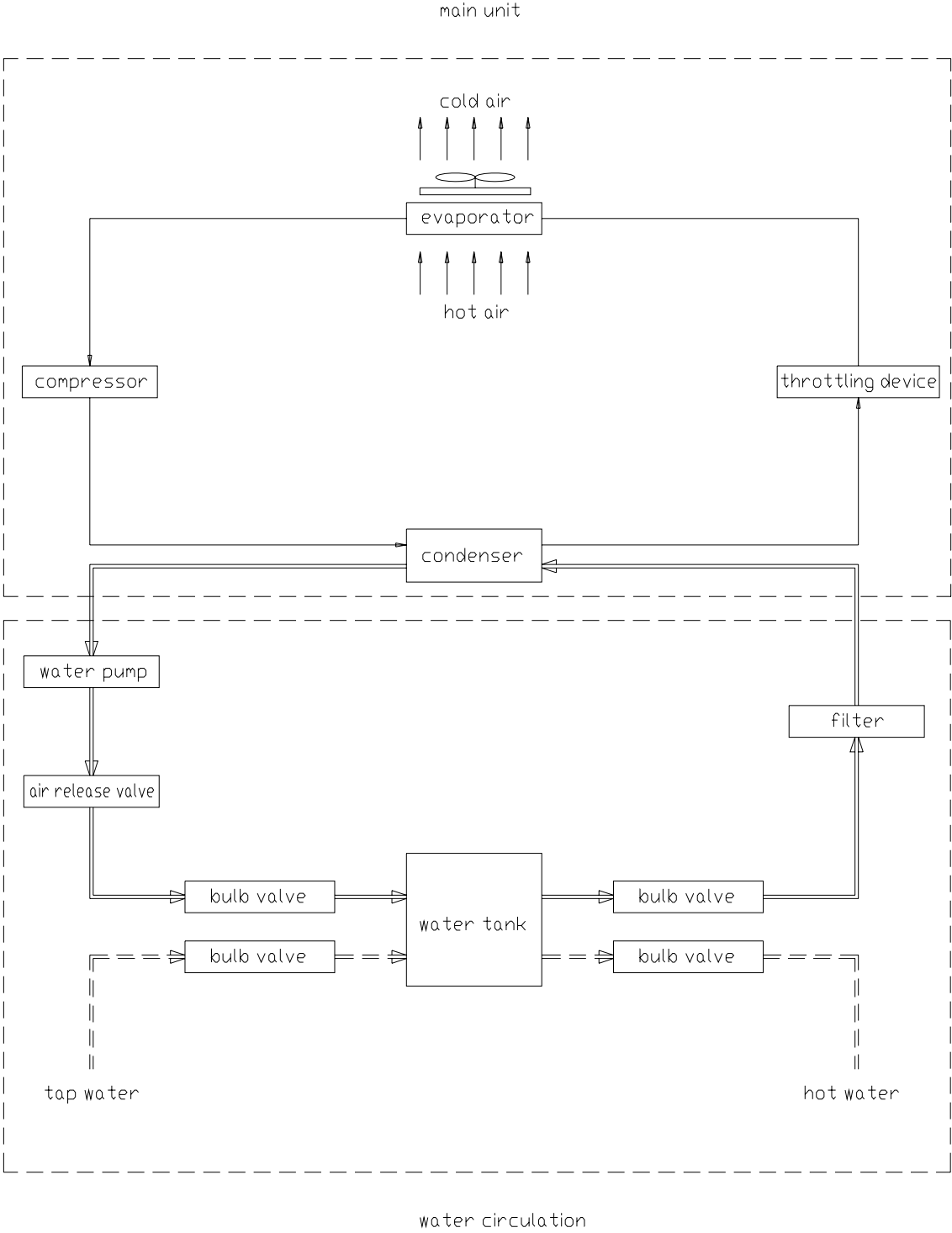

3. Technical Data Table

Model	RS-42P5A/T	RS-62P5A/T	RS-82P5A/T
Heating Capacity (W)	5200	7300	11500
Rated Input (W)	1290	1720	2580
Rated Current (A)	6.2	8.3	11.8
COP (W/W)	3.8	3.8	3.8
Max Input (W)	2100	2850	4500
Max Current (A)	10	13.7	21
Power Supply	220V ~ /50Hz		
Compressor Type	Rotary compressor		
Max Water Temp (°C)	55		
Operating Range (°C)	-8 ~ 43		
Hot Water Supply (L/h)	145	185	260
Pipe Diameter (inch).	3/4	3/4	3/4
Refrigerant	R410A		
Refrigerant Weight (g)	930	1000	1450
Size (L*W*H) (mm)	740×340×1020	740×340×1020	740×340×1020
Net Weight (Kg)	80	90	100
Noise (dB (A))	≤55	≤58	≤61

Note: 1. COP Performance refers to the following conditions:

2. Environment temp.: dry bulb: 20°C, wet bulb: 19°C;

Input water: 20°C, hot water: 55°C

3. The above data might change as the product improves; please refer to the details on the product nameplate.

4. Circuit drawing

RS-82P5A/T

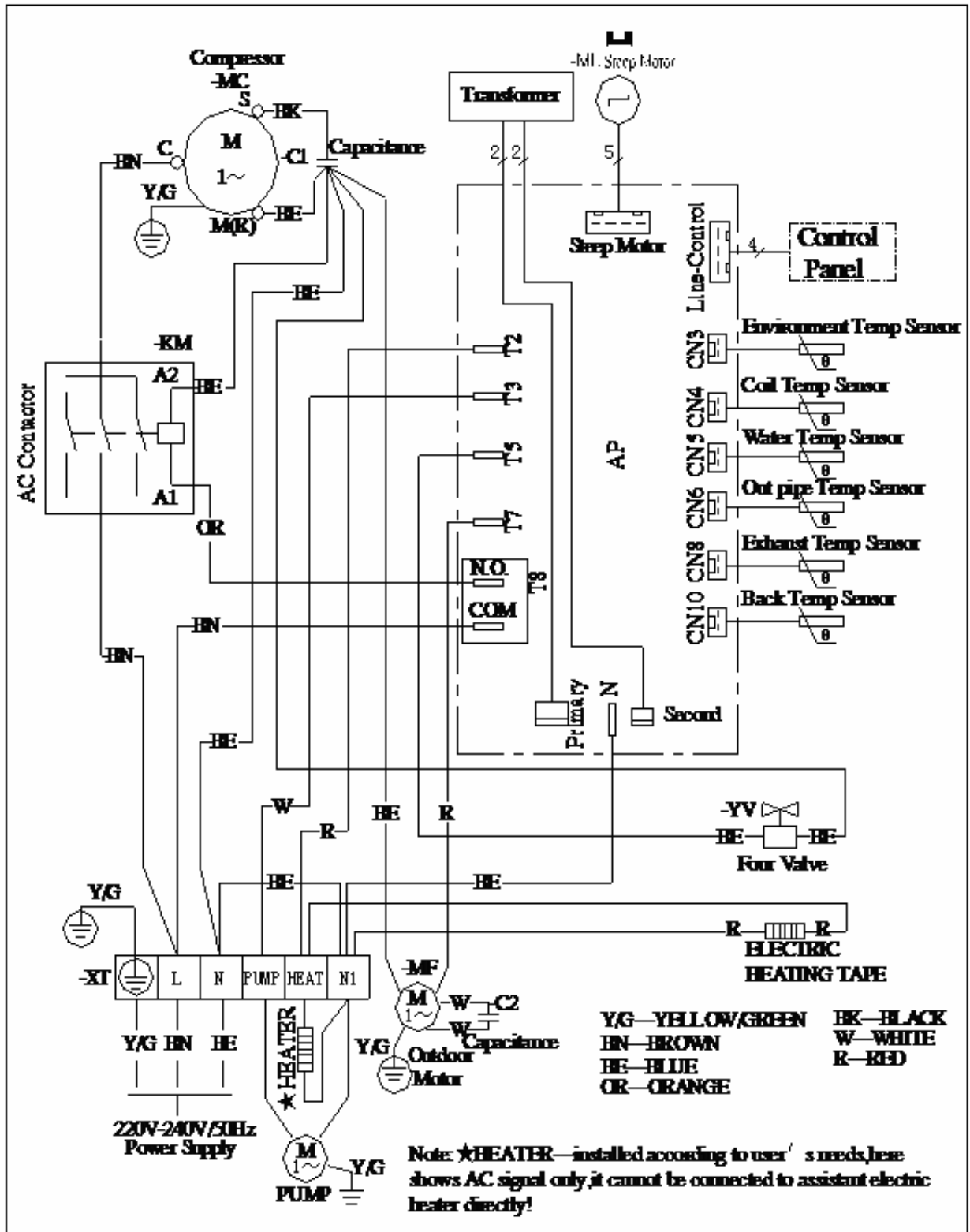

RS-62P5A/T RS-42P5A/T

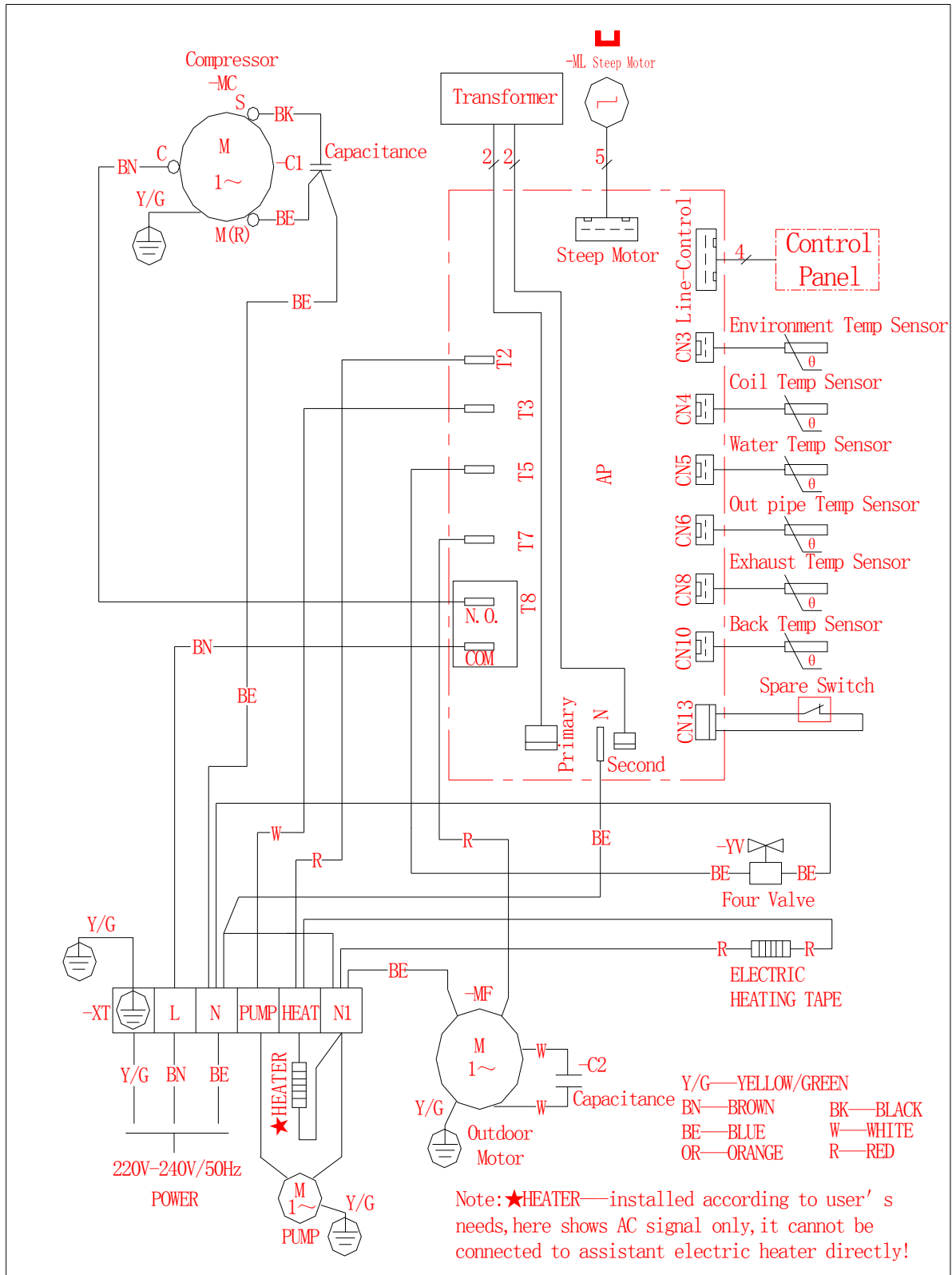

5. Installation and Debugging

5.1. Operating Conditions:

The unit operates normally under the following conditions:

Environment Temperature: -8°C - 43°C

Relative Humidity: $\leq 95\%$

Power Supply: 220V/-/50Hz

- Any conductive material, explosive gas, or corrosive gas that would damage the unit's metals or its isolation materials should not be in the vicinity of the unit.
- The unit is recommended to be installed outdoors

5.2. Transportation and Installation:

- During transportation the unit must be right side up and should not be inclined more than 30° degrees from the vertical.
- The unit must be positioned with clearance on the top and on both sides.

Refer to the diagram below. (P5.2.1)

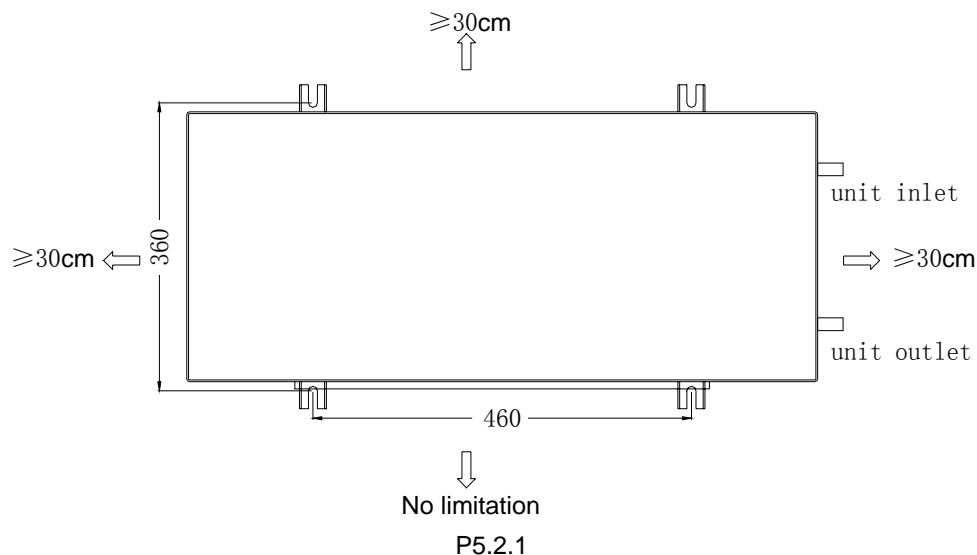

The AC input wire should be less than 5 meters long and the wire gauge should be $\geq 2.5\text{mm}^2$. Ground leakage protection is recommended and the unit should be well grounded (a 5 meter ground line is supplied with the unit).

Inlet and outlet pipe connections should be checked for leaks and any excessive pressure. A valve, filter and pressure gauge should be installed at the inlet side to control the input water pressure and flow. Refer to the installation drawing (page 4) for installation details.

The water pump must be installed according to installation drawing, its requirements are:

Unit Model	Requirements of the Water Pump
RS-42P5A/T	Water flow $\geq 2\text{ton/h}$ (33.3l/min), delivery lift $\geq 10\text{m}$
RS-62P5A/T	Water flow $\geq 3\text{ton/h}$ (50.1l/min), delivery lift $\geq 10\text{m}$
RS-82P5A/T	Water flow $\geq 4\text{ton/h}$ (66.6l/min), delivery lift $\geq 10\text{m}$

Note: the above data is only for reference; please ensure it according to installation place.

Drain all the water from inside the unit if it is not in use for a long period: this will prevent damage to the heat exchanger and the water pump.

5.2.1 Water drainage from inside the unit:

Remove the four screws at the bottom of the back plate and the drainage pan.

Take out the back plate and incline it 30° as shown in the pictures below,

Remove the plate by pulling it downwards,

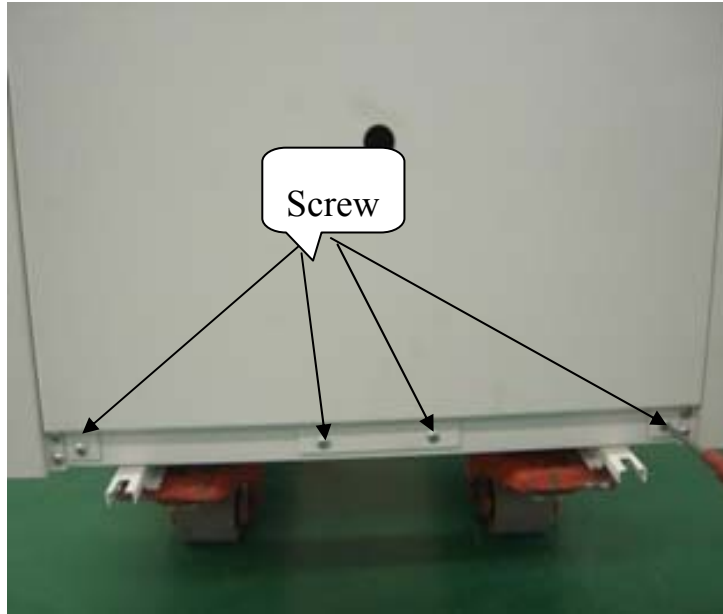

5.2.2 Turn the drainage knob on the bottom of double-pipe heat exchanger clockwise or counterclockwise rotating it through for 90°; the internal water will flow out through the knob.

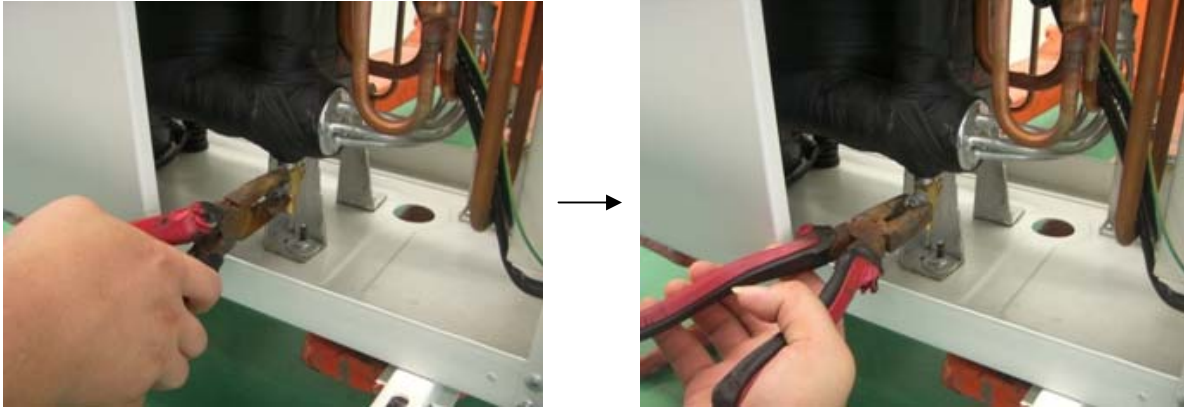

5.2.3 Return the knob to its original position once the water has drained.

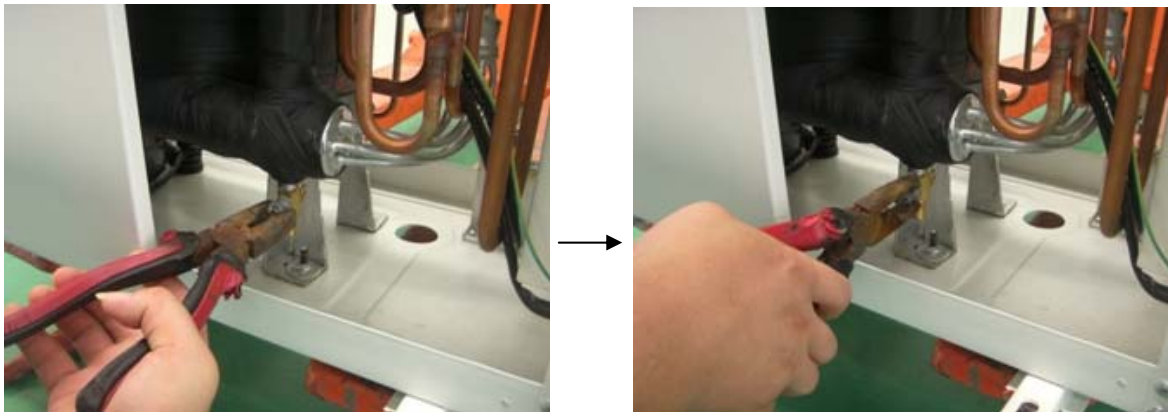

5.2.4 Replace the back plate and refit it to the drainage pan.



★Note on reuse; fill the water tank before applying power to the unit.

Discharge the condense water and defrost water through pipes to the outdoor.

5.3 System Connection:

Water supply system design may require according to different needs which will be carried on by our company. To make an isolation water tank, install pressure pump or circulation pump, valve, filter, electromagnetic valve, bulb valve, and one-way valve, etc. Pipes will be laid with isolation. All these are to be control by a control box to make a hot water supply system.

5.4 Debugging:

Each unit has been tested before leaving the factory. Users do not need to make any changes. Ensure correct connect of the unit to the outdoor water circulation system. Then connect the power supply and check if there is any damage or leaks. After that the unit is ready to be switched on.

The debugging processes are:

5.4.1 Fill the water tank to a demand height, open all the valves and empty the whole waterway system, be sure there is no gas inside, or it will cause malfunction of water pump and unit.

5.4.2 Check that wire connections are correct; Refer to the circuit diagram.

5.4.3 Set the water temperature; refer to the Controller Instructions section. A water temperature of 50-55°C is recommended for the summer and autumn months, while 50-60°C is recommended in the spring and winter months.

5.4.4 Press the “on/off” button for 3 seconds, the fan motor and water pump will start first. The compressor starts 1 minute later and begins to heat the water. If an assistant electric heater element is installed, the electronic control system may

activate the assistant heater element depending on the outdoor temperature. No user intervention is required.

5.4.5 The system automatically checks air release, air return, coil, and water temperature while the unit is operating. If an error occurs, the error code is displayed.

5.4.6 The compressor stops running when the water reaches its set temperature, the fan motor and the water pump stop 1 minute later.

5.4.7 Defrosting is done automatically when the external temperature is too low. The defrost process is begun depending on the pipe temperature.

6. Controller Operation/Instruction

6.1 Functions of the control buttons

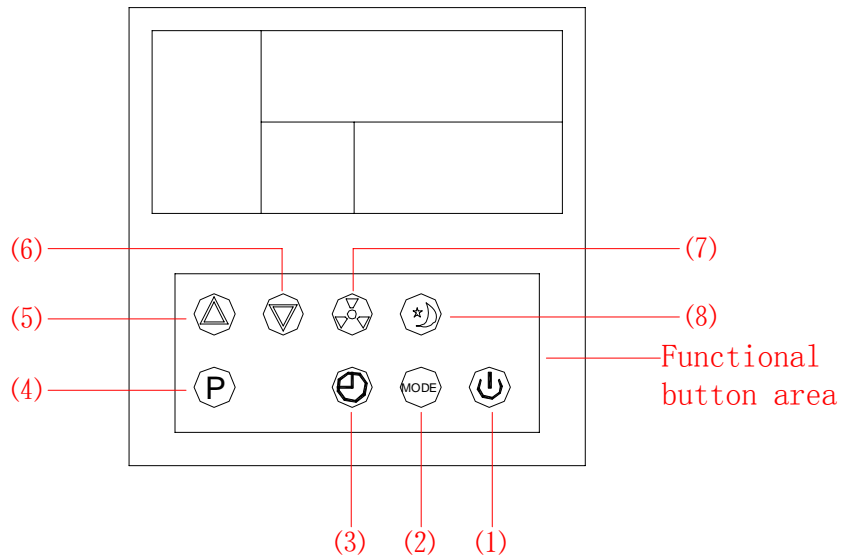





- | | |
|--------------|------------------|
| (1)---On/off | (5)---Temp/Time+ |
| (2)---Mode | (6)---Temp/Time- |
| (3)---Timer | (7)---Fan Speed |
| (4)---Reset | (8)---Sleep |

- ⬆ : Adjust Temperature or Clock (press once to add 1).
- ⬇ : Adjust Temperature or Clock (press once to reduce by 1).
- ⌘ : In the Check mode, press once to show data.
- ☾ : Non Functional
- P : Check/Set button
- ⌚ : Timer or clock set
- MODE : Press for 5 seconds to enter Temperature Set mode
- ⏻ : On/off button

6.1.1 Temperature Set

6.1.1.1 Press  once, the unit is powered on in the Work mode;



6.1.1.2 Press  for 5 seconds, the “Set Temp” sign is flashing and the unit enters Temperature Set mode;



6.1.1.3 Press  or  to add or reduce 1°C, the default temperature is 55°C and the setting range is 20-70°C. Press  to return the display to the current water temperature.

6.1.1.4 Press  once to power off the unit; note the set temperature will be saved.

6.1.2 Timer and Clock Settings

6.1.2.1 The timer and clock can be set in working or non-working mode

6.1.2.2 Press  to enter timer “off hour” setting, “off” and “timer” appears on the display while “hour” flashes, press  or  to adjust the required off hour;

6.1.2.3. Press  again to enter “minute” set, “off” and “timer” appears on the display area while “minute” flashes, press  or  to adjust the required off minute;

6.1.2.4 Press  to set, or the set time will be unavailable; or, set the off “hour” after step “6.1.2.1”, then the minute will be the default number;

6.1.2.5 After setting the off time, press  to set the on time. Enter the off

time first, and then press \ominus twice to enter the “on hour” time, “on” and “timer” appears on the display while “hour” flashes, press \triangle and ∇ to adjust the required on hour;

6.1.2.6 Press \ominus again to enter “minute” set, “on” and “timer” appears on the display area while “minute” flashes, press \triangle or ∇ to adjust the required on minute;

6.1.2.7 Steps “6.1.2.5” and “6.1.2.6” will be set after press of \textcircled{P} , see step “6.1.2.4”:

6.1.2.8 Both Timer on and Timer off must be set. If only one is set, the unit timer setting will default to “00: 00” and it will require manual intervention to turn the unit on or off depending on which setting has not been activated.





6.1.2.9 Controller Clock Setting: Press \ominus 5 times (jumps over timer off and timer on settings) in the on/off mode and enter the clock set mode while the “hour” flashes, press \triangle or ∇ to set “hour” of the clock. Press \ominus again and “minute” flashes, and then press \triangle or ∇ to set “minute”. Finally press \textcircled{P} to complete the setting.

6.1.2.10 Delete timer on/off function:

Reset the timer on/off time to “00: 00” to delete the set time.





6.1.2.11 The Clock and Timer setting range is 24 hours (“hour” is 0-23 while minute is 0-59).

6.1.3 Temperature Check Function

Press  for 10 seconds and “temp set” flashes, the lower part of the display area shows the temperature. Press  once and a sequence of data is displayed; intake temperature, pipe temperature, electric valve open angle (which is multiplied by 8), water temperature, air release temperature, ambient temperature, outlet pipe temperature, 00, and 00; for a total of 7 relevant data points. Press  again and the data is displayed again. Press  to exit the temperature check. While displaying temperature, if the sign “+” appears, it means the temperature is a positive number or “-” for a negative one. If the data is greater than 100 the two most significant digits are replaced by a hex digit (A is 10 decimal, B is 11, C refers to 12 so for example B3 means 113).

Note: While this function is active the unit cannot be powered down. The user must exit this function to power down the unit.

6.1.4 Temperature Set:

Press  for 5 seconds and temperature set flashes, press  or  to set temperature, then press  to exit.

6.1.5 Error Reset Function

Reset function tries to reset error conditions on the unit.

When an error occurs, button  is used to determine if the error has been reset.

Press  and if the LCD display resets to its original normal operating state, then the error has been reset; if the error still exists then only the alarm has been reset.

6.1.6 Fan Speed Set:

Pressing  has no function on these units; these units do not have a fan speed function. This button only functions under the temperature check mode, pressing once to sequence through the data.

6.1.7 Sleep button: The button is non-functional on these units.

6.2 Controller display

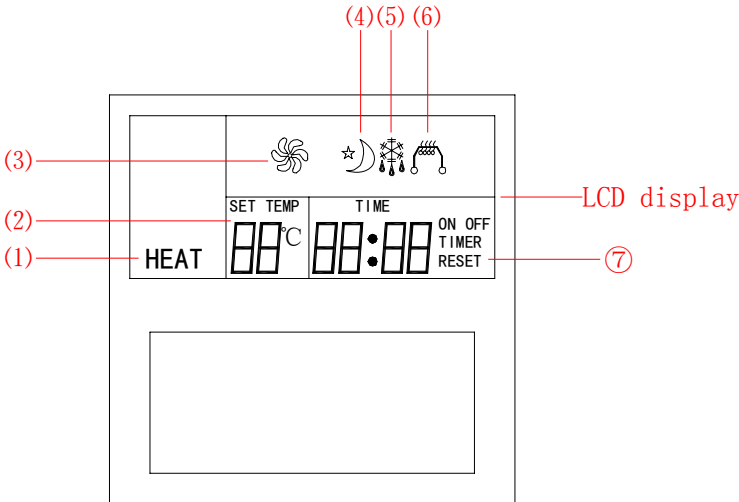

- (1)---Heating
- (2)---Temp
- (3)---Fan speed
- (4)---Sleep
- (5)---Defrosting
- (6)---Electric heater
- (7)---Time

6.2.1 Power Off Display

The unit displays the current water temperature and time.

6.2.2 Power On Display

The unit displays the current water temperature, time, current working mode “HEAT” (these units have only a heating function), working mode of the fan motor, electric heater element, compressor, etc.

Under Temperature Set mode, the display always shows the hot water temperature except when actually setting the temperatures. The current water temperature is shown when the unit is powered off.

6.2.3 Defrosting

The defrosting symbol  indicates that defrosting is in progress.

6.2.4 Assistant Electric Heater Element:

The assistant electric heater element symbol  indicates the element is on.

6.2.5 Error Code Display:

When an error occurs, an E:XX appears on the time display area.

6.3 Protection Function:

6.3.1 Air Release Temperature (compressor overheat protection)

When air release temp of compressor $\geq 120^{\circ}\text{C}$, outdoor compressor, fan motor, and water pump will not restart automatically;

6.3.2 Communication Protection

If a communication error lasts for one minute between the outdoor unit and the controller then error code E19 appears and the unit stops operating.

6.3.3 Water Pump Anti-freezing:

To prevent external pipe freezes while in the ready to power on mode, if the water outlet pipe temperature is sensed $\leq 3^{\circ}\text{C}$ for one minute then the water pump is activated. If this temperature is sensed to be $\geq 12^{\circ}\text{C}$ then the water pump is deactivated.

7. Maintenance

The unit is equipped with various safety protection functions. The unit will automatically restore itself in the case of a fault. It requires regular checks on a number of system components.

The installation site should be well ventilated in order that the capacity of unit is not affected.

Depending on the climate, each month the user should check if the surface of evaporator is clean; if not, the surface should be cleaned with water and a cloth.

If the condensed water drainage pipe is blocked then the water drainage pan will overflow. It also requires for regularly checking and cleaning. – Need to clarify by checking our unit

If the condensed water drainage pipe (a steel pipe goes through the middle horizontal plate and the underpan) is blocked then the water drainage pan (the middle horizontal plate) will overflow. It also requires for regularly checking and cleaning with a thick stick or by blowing with high pressure.

8. Troubleshooting

As mentioned before the unit is equipped with various safety protection functions. Error codes indicate where the error occurred. If following regular maintenance, there is any reoccurring error please notify the supplier.

Self-Diagnostic error function (controller display)

The Error code shows on clock display area when the error occurs:

Error code “00” refers to no error;

Error Alarm and Diagnose Table:

Frequent errors:

Error	Cause	Diagnostic method and measurement
Compressor stops	Power supply not connected	Check power supply wiring and switches
	Controller not switched on	Press the power on button
	Controller shows error code	Check corresponding error code
Water temp not going up	Heat exchanger covered by dust	Clean heat exchanger
	Ambient temperature is too low	Ensure the temperature is not outside operating range
	Refrigerant leakage	Check/Fix leakage, have unit refilled with refrigerant by service personnel
No Controller display	Power supply not connected	Check power supply wiring and switches
	Controller display flickering not well connected or cut	Check if power supply wire or plug is loose
Not producing heat, unit blows hot air	Four-way valve damaged	Have the four-way valve changed by service personnel
Fan motor not running	Fan motor or capacitor damaged	Service personnel check if the motor loop or capacitor is damaged and change it.
	Wires loose	Service personnel ensure all connections are secure.

System Error Codes refer to the following table:

Serial No.	Error code	Error Description	Troubleshooting
1	E02	Water temp. sensor circuit shorted or broken	Check the sensor resistance with a multimeter; if it has a resistance it is OK, if it is shorted or open it is broken. Change the sensor if damaged; check if the connector is loose or broken; manually reset the unit
2	E03	Ambient temp. sensor circuit shorted or broken	Check the sensor resistance with a multimeter; if it has a resistance it is OK, if it is shorted or open it is broken. Change the sensor if damaged; check if the connector is loose or broken; manually reset the unit
3	E04	Coil temp. sensor circuit shorted or broken	Check the sensor resistance with a multimeter; if it has a resistance it is OK, if it is shorted or open it is broken. Change the sensor if damaged; check if the connector is loose or broken; manually reset the unit
4	E12	Intake temp. sensor circuit shorted or broken	Check the sensor resistance with a multimeter; if it has a resistance it is OK, if it is shorted or open it is broken. Change the sensor if damaged; check if the connector is loose or broken; manually reset the unit
5	E14	Compressor air release temp. sensor circuit shorted or broken	Check the sensor resistance with a multimeter; if it has a resistance it is OK, if it is shorted or open it is broken. Change the sensor if damaged; check if the connector is loose or broken; manually reset the unit
6	E16	Compressor air release temp. overheated alarm	Check the system and delete the error; reset the unit by cycling the power off and on.
7	E19	Controller communication error	Check the controller is operating normally; manually reset the unit
8	E21	Water Outlet temp. sensor circuit shorted or broken	Check the sensor resistance with a multimeter; if it has a resistance it is OK, if it is shorted or open it is broken. Change the sensor if damaged; check if the connector is loose or broken; manually reset the unit
9	E29	Unit communication error	Check the main control board is operating normally and manually reset the unit

9. Note:

After the installation of heat pump, please add on a flashing shed to prevent rain or snow from dripping directly onto the machine and affect the operation.

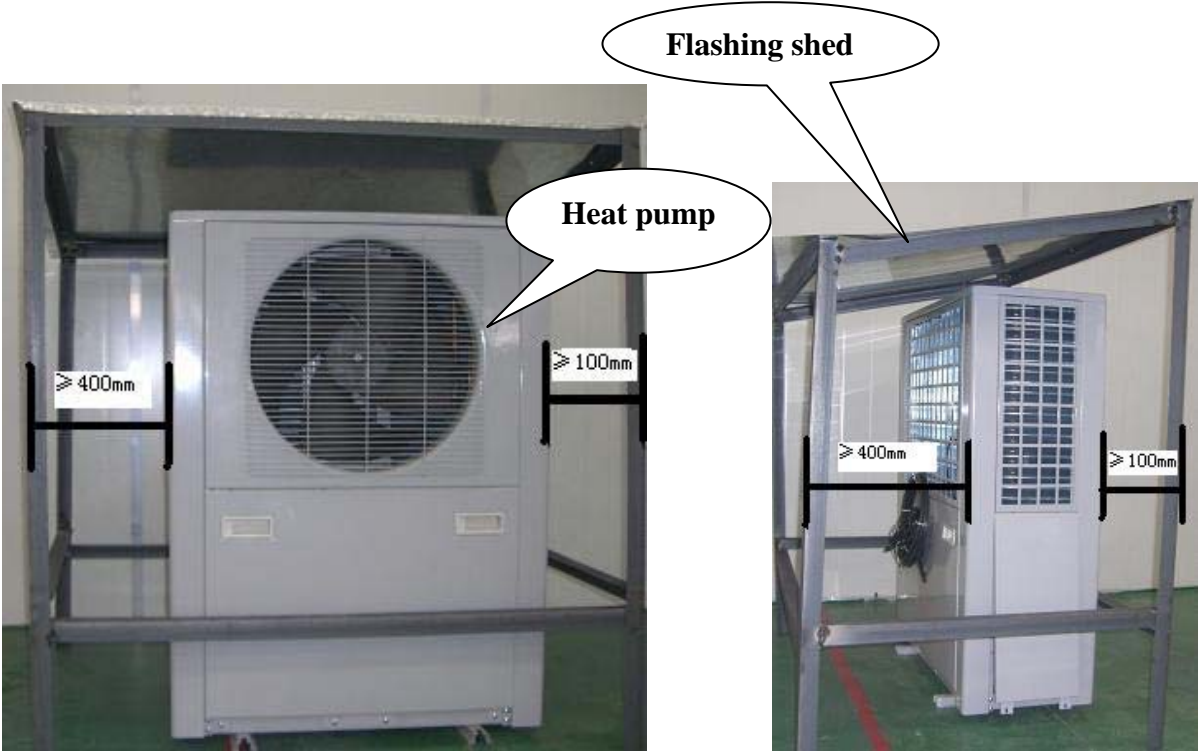

Requirement of the flashing shed:

It must cover the whole unit, with the size: front of shed 100mm over front of heat pump; back of shed 400mm over back(with net) of heat pump; right side of shed 100mm over right side of heat pump; left side of shed 400mm over left side(with net)of heat pump. The details are specified on the pictures.